

342577 (Coibentata - Isolee
Insulate Isoliert - Aislamiento)
342576

180642

361097
200925

160811
190638
190637

390199
180642
361096

411002

352191

390199

351421

342575

320543

120348
324303

352186

351422

440211

11 - 2009 M. S.

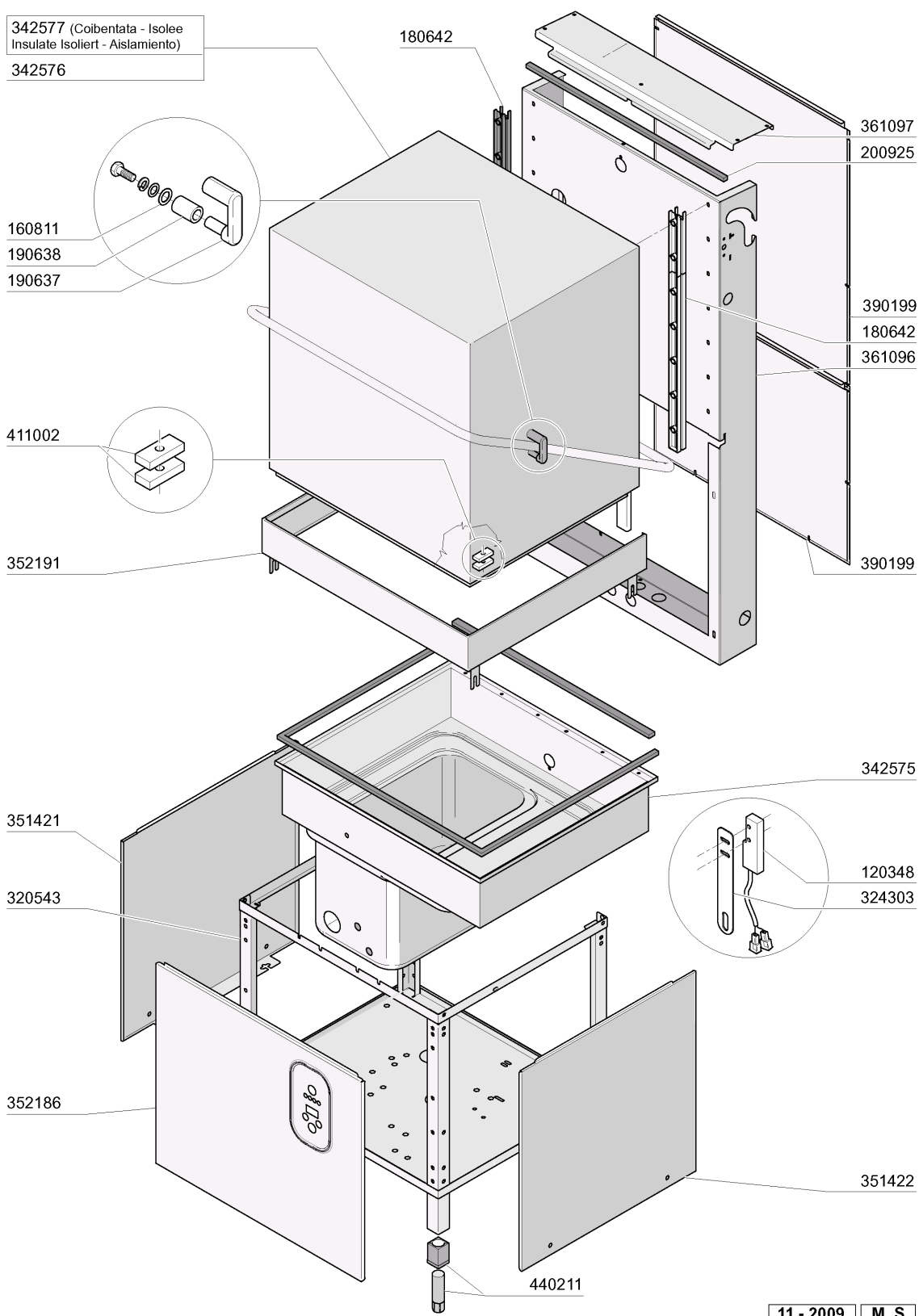

1 - Hood

CODE	DESCRIPTION
120348	MAGN.SWITCH (N.O.)
160811	WASHER F2 18X8.5X1 ALGOF
180642	GUIDE
190637	GUIDE FOR DOOR "C"
190638	ROLLER FOR "C" DOOR GUIDE
200925	GASKET
320543	LOWER FRAME XLC
324303	FIXING BRACKET
342575	TANK XLC
342576	HOOD XLC
342577	INSULATED HOOD XLC
351421	LEFT PANEL
351422	RIGHT PANEL
352186	FONT PANEL XLC
352191	PANEL XLC
361096	POSTERIORE TELAIO XLC
361097	UPPER BACK COVER XLC
390199	BACK PANEL XLC
411002	PERMANENT MAGNET 24X12
440211	LEGS

2 - Tank

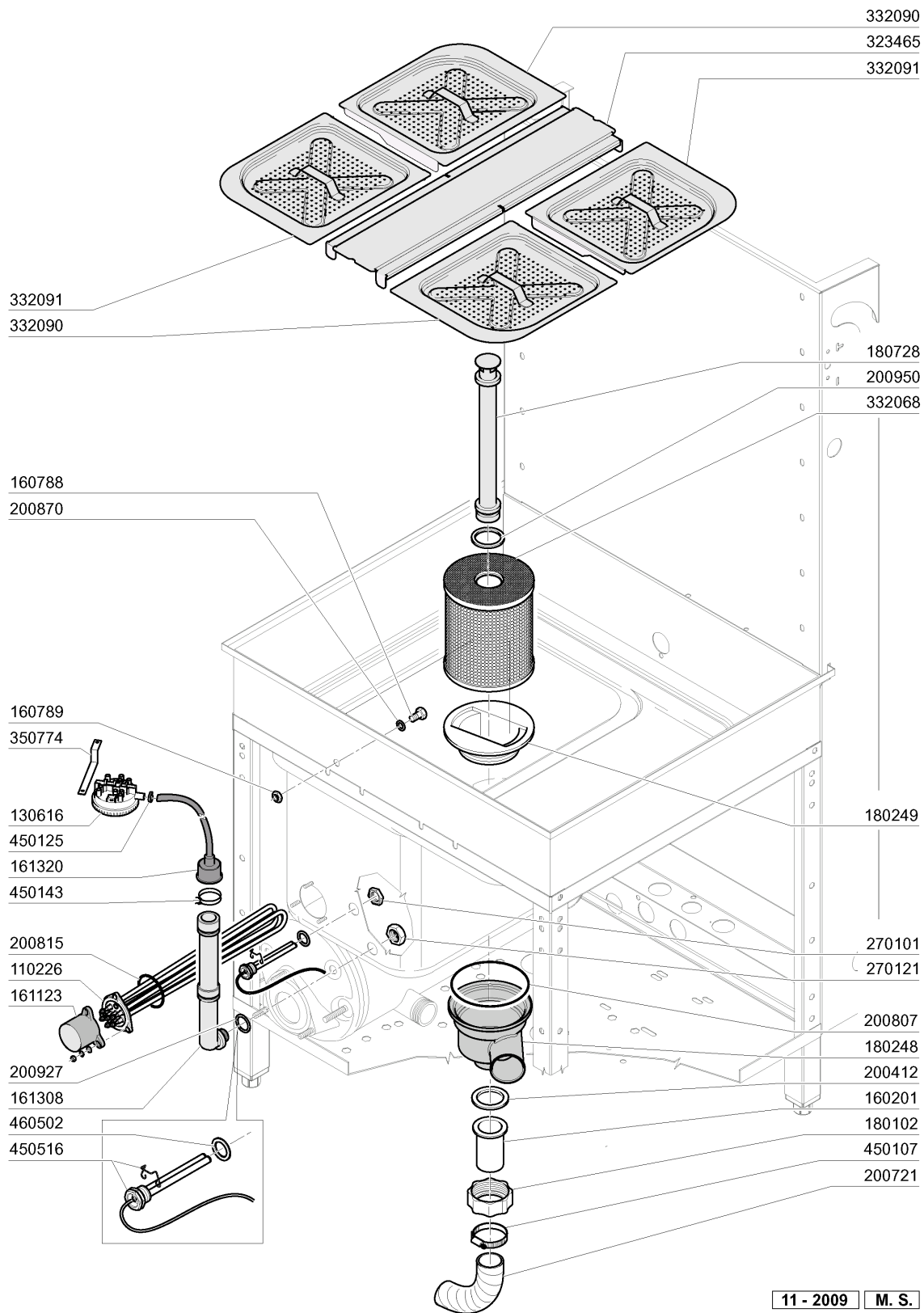

2 - Tank

CODE	DESCRIPTION
110226	HEAT. ELEMENT 3000W 230/400V
130616	PRESSURE SWITCH 190/80 FOR C95
160201	ELBOW F.TANK INLET MOPLN
160788	PLUG
160789	NUT
161123	HEAT.ELEMENT COVER H42 SNL
161308	AIR CHAMBER C95-155
161320	HOSE FOR AIR CHAMBER
180102	DRAIN PIPE NUT 1"1/2 F45-55
180248	SUCTION TANK
180249	NUT
180728	OVERFLOW PIPE
200412	GASKET DRAIN 11/2" 45X33X3
200721	DRAIN HOSE 28X35 2MT.
200807	O-RING 3,53 X 110,72
200815	O-RING F. HEAT.ELEM.
200870	GASKET 18X10X2
200927	GASKET FOR AIR TRAP
200950	VITON GASKET
270101	HEXAGON LOCK NUT 1/2"
270121	NUT FOR AIR TRAP
323465	STRAINERS SUPPORT
332068	STRAINER
332090	RIGHT STRAINER
332091	TANK LEFT STRAINER
350774	BRACKET
450107	CLAMP FE ZN 38-50 H=12,2
450125	ELASTIC CLAMP D. 10,4X9,8
450143	CLAMP D.39,7 X 37,7
450516	THERMOSTAT SHIELD FOR 2 TERMOS
460502	GASKET 30X21X2

3 - Handle

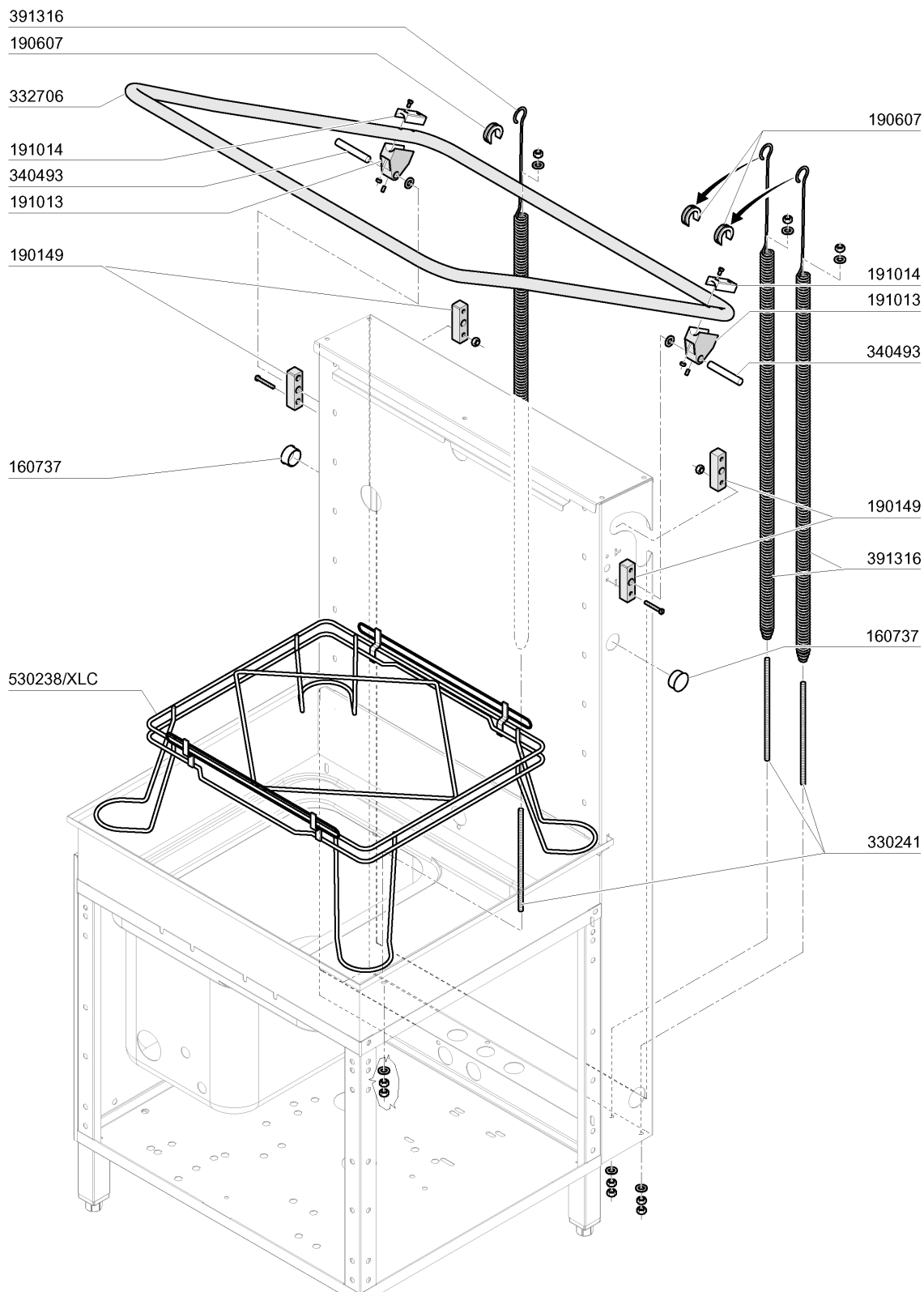

11 - 2009 M. S.

3 - Handle

CODE	DESCRIPTION
160737	PLUG HEYCO D.34,9
190149	REINFORCEMENT FOR HANDLE SUPP.
190607	HANDLE BUSH C30-70
191013	HINGE F. SUPPORT C30-C70
191014	FLANGE F. HANDLE C30-70
330241	SPRING ROD
332706	HANDLE XLC
340493	PIN F. HINGE C30
391316	SPRING FOR HANDLE C85/140-G75
530238/XLC	RACK SUPPORT

4 - Wash and rinse column

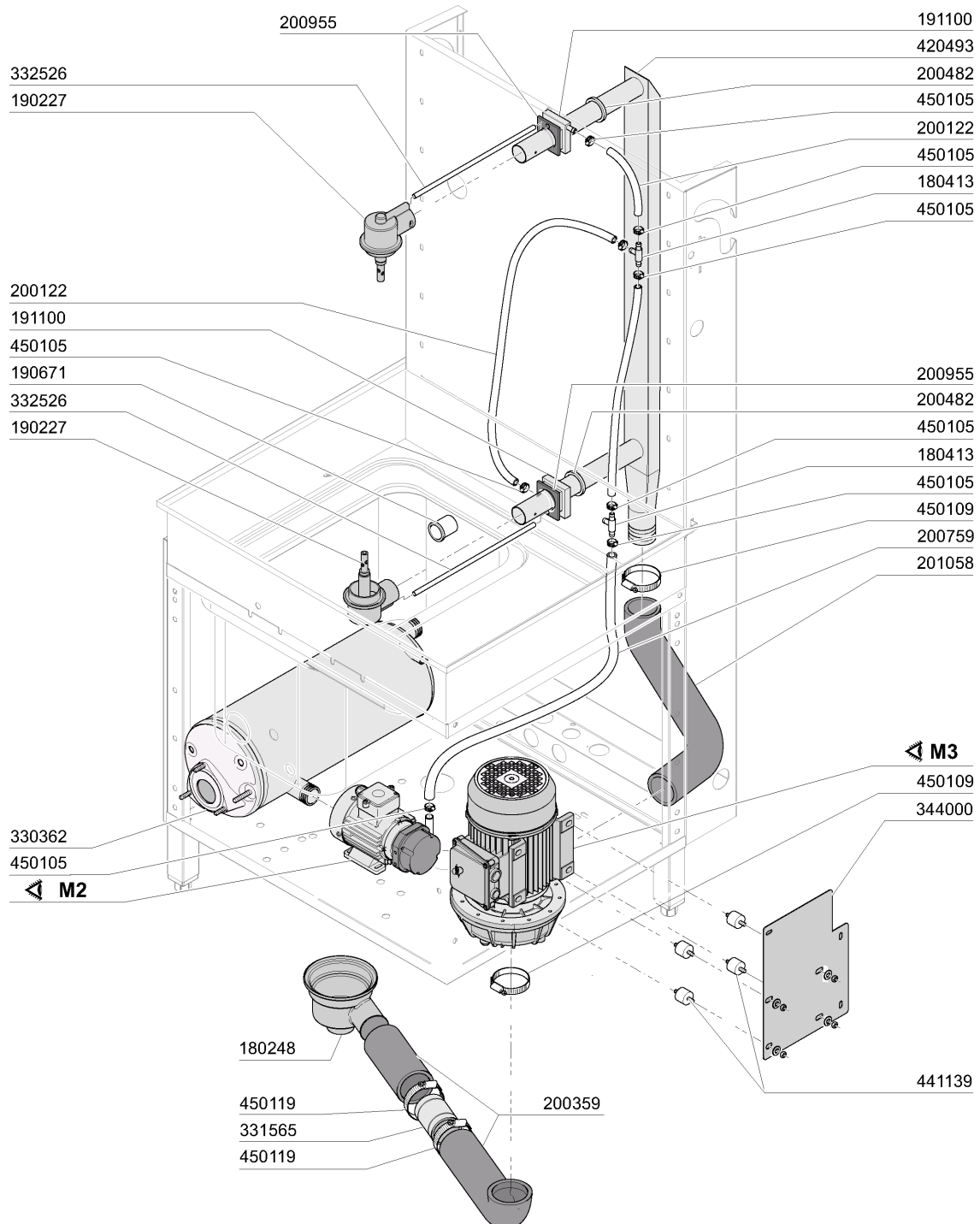

4 - Wash and rinse column

CODE	DESCRIPTION
180248	SUCTION TANK
180413	TEE NIPPLE D.11,5 - RINSE ASSE
190227	ARM SUPPORT
190671	BUSH
191100	RINSE COLLECTOR C-LC
200122	HOSE 11X19
200359	INLET HOSE C34-S
200482	GASKET 60X54 RAMP C140
200759	DELIVERY HOSE FOR ECORINSE AC-
200955	GASKET
201058	OUTLET HOSE
330362	BOOSTER FOR BREAK TANK
331565	INLET ELBOW FOR AC/ACR WASH PU
332526	RINSE HOSE
344000	PUMP SUPPORT
420493	WASH COLUMN XLC
441139	VIBRATION-DAMPING FEET 25X20X6
450105	CLAMP FE ZN. 26-38 H=12,2
450109	CLAMP 50-65
450119	CLAMP FE ZN. 58-75 H=12,2

5 - Wash arm

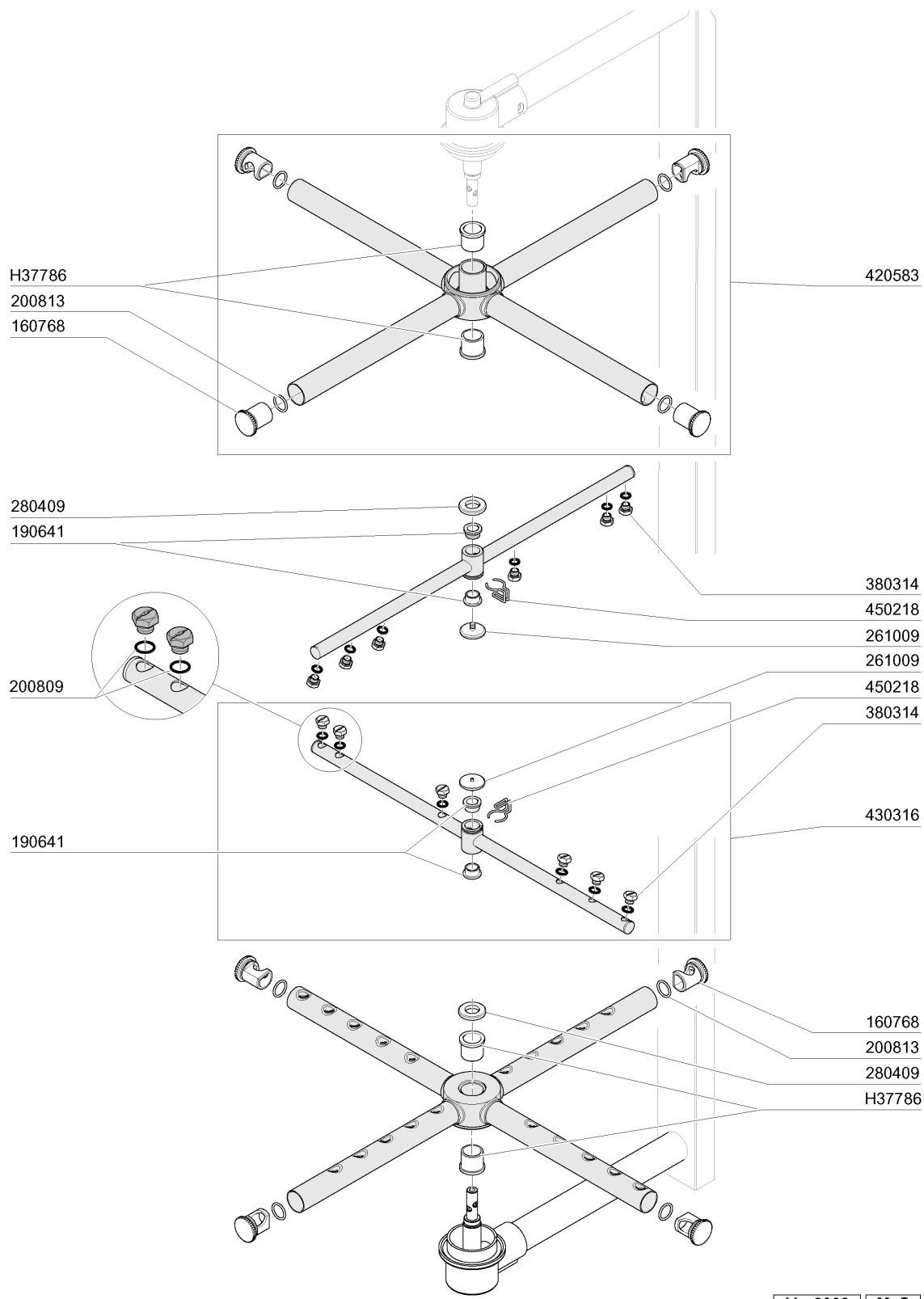

11 - 2009 M. S.

5 - Wash arm

CODE	DESCRIPTION
160768	PLUG FOR "C95-155" WASH ARM
190641	BUSH FOR C95-155-165 RINSE ARM
200809	OR GASKET 1,78X8,73X12,29
200813	OR GASKET 2,21X16,36X20,78
261009	RETAIN.SCREW FOR WASH-RINSE AR
280409	RETAIN.LOCK NUT CENTR.CROSS C1
380314	RINSE JETS 801/HR
420583	WASH ARM XLC
430316	RINSE ARM FOR C95-C155-C165
450218	SPRING F.RINSE ARM RETAIN.SCRE
H37786	WASH ARM BUSH

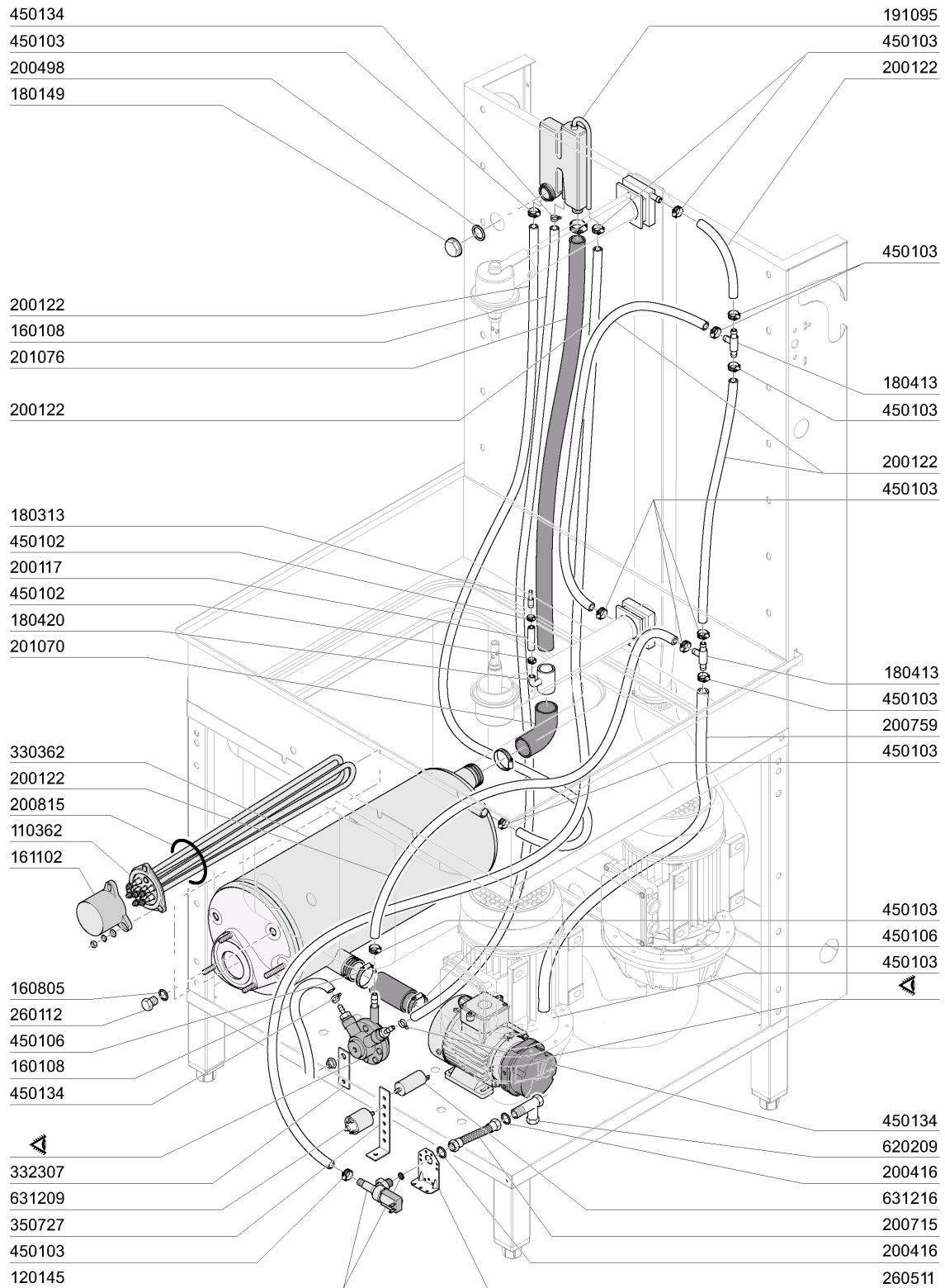

CODE	DESCRIPTION
110362	HEAT.ELEMENT 9000W 220/380V
120145	SOLENOID VALVE 12 LT 1 WAY
160108	INJECT.INLET HOSE D.8X5
160805	GASKET D.8
161102	ELEMENT COVER MOPL.
180149	PLASTIC NUT
180313	TEE-NIPPLE
180413	TEE NIPPLE D.11,5 - RINSE ASSE
180420	TEE-NIPPLE
191095	CONTAINER FOR BREAK TANK
200117	RUBBER HOSE 7X16
200122	HOSE 11X19
200416	GASKET D. 3/4"
200498	GASKET
200715	HOSE WATER INLET 2M STAINL.ST
200759	DELIVERY HOSE FOR ECORINSE AC-
200815	O-RING F. HEAT.ELEM.
201070	HOSE
201076	HOSE
260112	STAINLESS STEEL TE-SCREW 8X16
260511	GROWER WASHER D.5
330362	BOOSTER FOR BREAK TANK
332307	BRACKET
350727	BRACKET
450102	CLAMP FE ZN 11-17 H=9
450103	CLAMP FE ZN. 13-20 H=9
450106	CLAMP FE ZN 32-44 H=12,2
450134	ELASTIC HOSE CLIP D.9,3/8,8
620209	INLET WATER FILTER
631209	ANTI-NOISE FILTER
631216	CAPACITOR 6.3 MF 450V

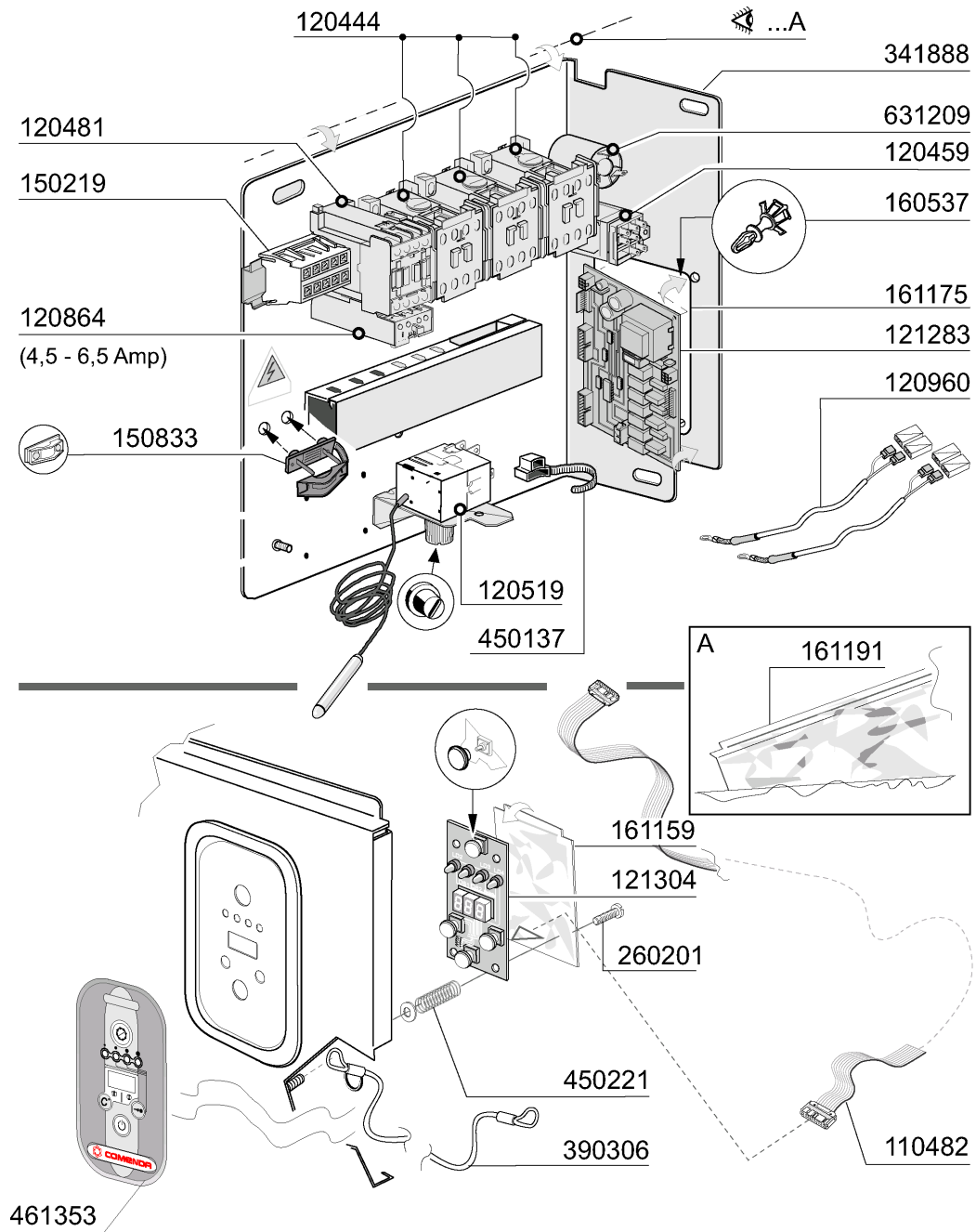

11 - 2010 | M. SA.

7 - Control Box

CODE	DESCRIPTION
110482	CABLE FOR PCB FC-C-GE
120444	CONTACTOR 9A 220V 50HZ
120459	AUXIL.RELE 16A 220V
120481	CONTACTOR 9A-230V 50/60HZ
120519	SECURITY THERMOSTAT 95-125Ø
120864	OVERLOAD RELAY ABB 4,5-6,5A
120960	PROBE C-G
121283	ELECTRONIC PANEL "C-GE"
121304	C-GE 2009 PCB
150219	TERMINAL BLOCK 5P MMQ165VD26
150833	CABLE HOLDER BC/BR
160537	ELECTRONIC CARD SPACER
161159	PROTECT. COMMANDS SWITCHBOARD
161175	PROTECTION
161191	CONTROL BOX COVER
260201	SCREW TCP 3X10
341888	CONTROL BOX SUPPORT
390306	CABLE
450137	COLLAR CONNECTION WITH BASE 31
450221	SPRING FOR ELECTRONIC TIMER
461353	PLATE C-GE ELECTRONIC
631209	ANTI-NOISE FILTER

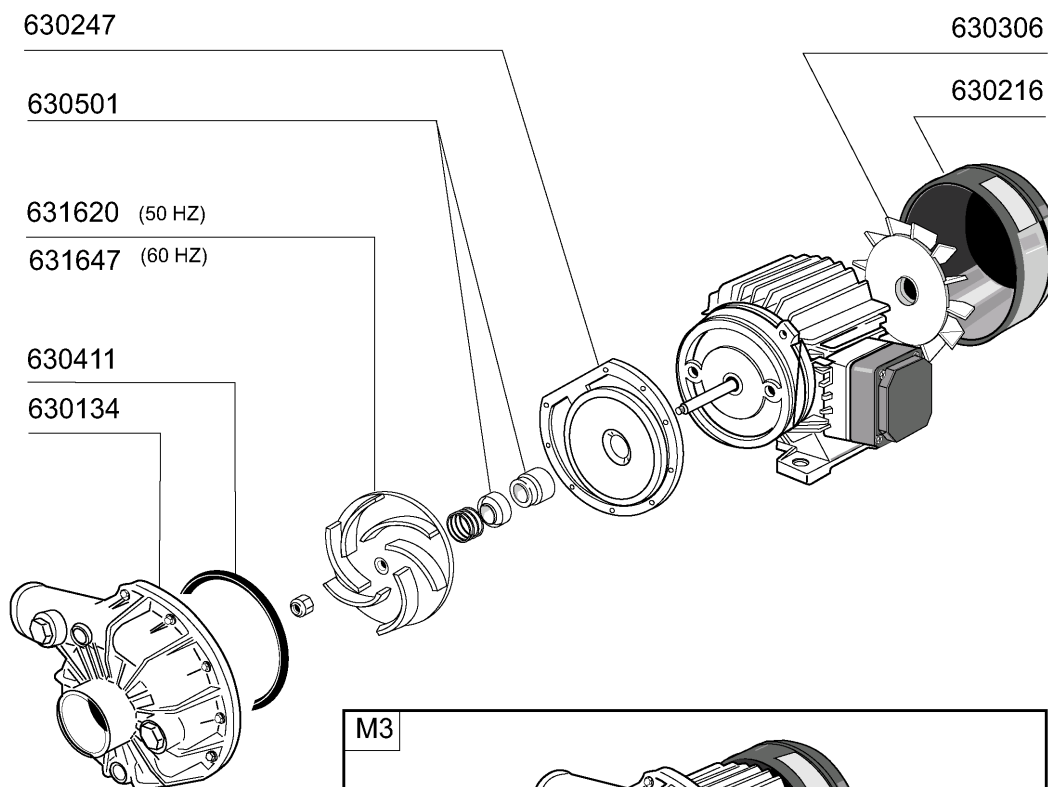

M3				
	COD.	V	Hz	POTENZA
STANDARD	100786	380 V/3	50Hz	HP 3-Kw 2,2
	100837	440 V/3	60Hz	HP 3-Kw 2,2
SPECIAL	100786/1	380 V/3	60Hz	HP 3-Kw 2,2
	100786/2	208 V/1	60Hz	HP 3-Kw 2,2

11 - 2010 | M. SA.

8 - Pump

CODE	DESCRIPTION
100786	PUMP HP 3 V.230-400-50HZ
100786/1	PUMP HP 3 230/400V 60HZ
100786/2	PUMP HP 3 208V 60HZ
100837	PUMP HP 3 250/440V 60HZ
630134	PUMP VOLUTE FIR 3HP
630216	FAN HOUSING FIR HP 2-3
630247	COPERCHIO IXEF POMPA FIR 3HP
630306	PUMP FAN IMPELLOR FI HP 2-3
630411	O-RING PUMP FI HP 2-2,7
630501	SEAL FOR PUMP HP 2-3-3,2
631620	IMPELLER HP 3-3,2 1205-43
631647	IMPELLER D.100-60HZ-1204/5

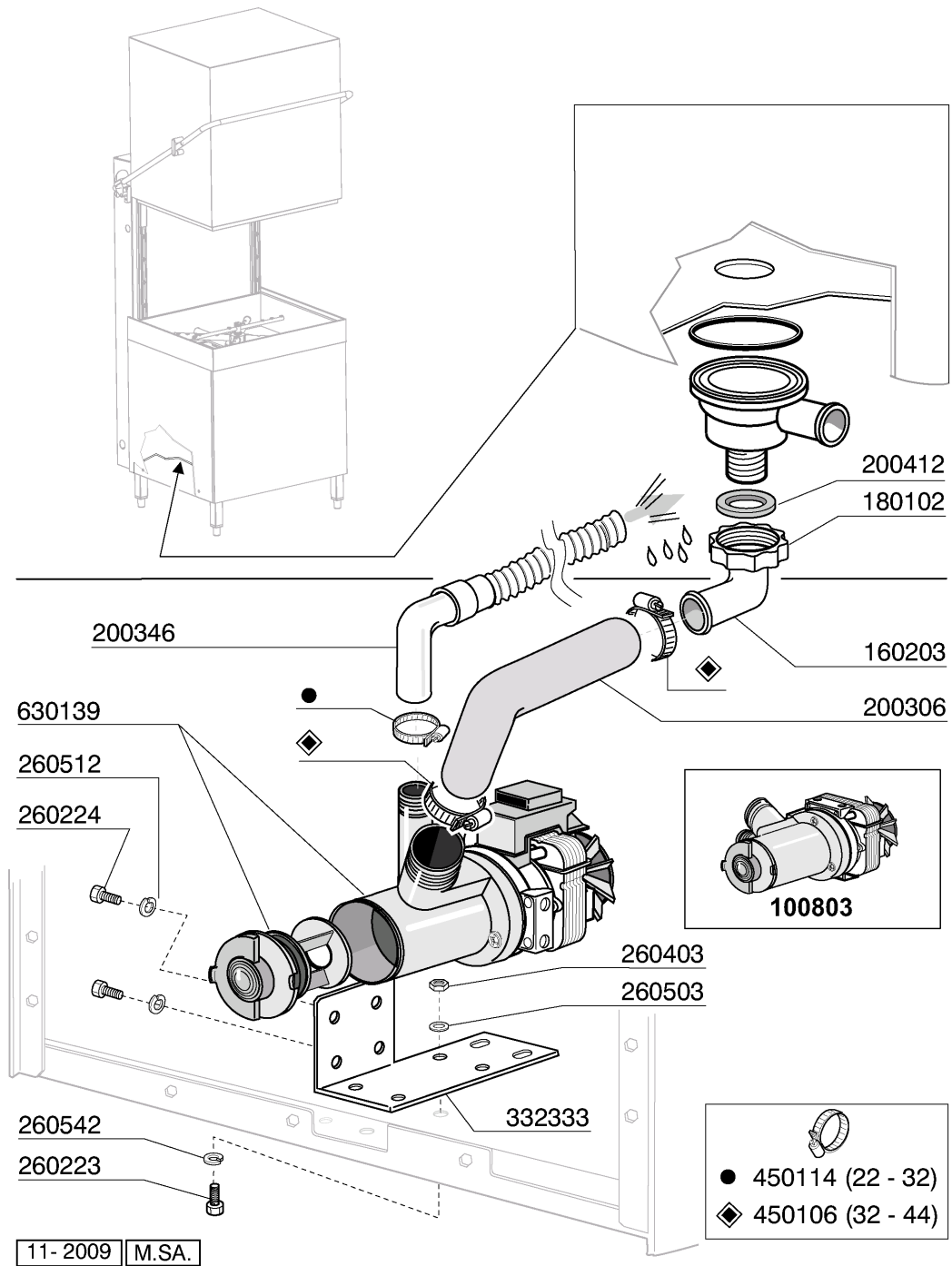

9 - Drain pump kit

CODE	DESCRIPTION
100803	DRAIN PUMP WITH FILTER 220/50
160203	ELBOW 1"1/2 N-S-F-C /DRAIN
180102	DRAIN PIPE NUT 1"1/2 F45-55
200306	INLET HOSE 42X52 ECORINSE-DRAI
200346	DRAIN HOSE GLASSWASHER
200412	GASKET DRAIN 11/2" 45X33X3
260223	M5X12 MSH/HD SCREW SPECIAL S/S
260224	TB-SCREW 6X15 B23-10-11-12
260403	NUTS D.5
260503	STAINL.STEEL FLAT WASHER D5 UN
260512	ST/ST GROWER WASHER D6
260542	WASHER D.5
332333	BRACKET FOR DRAIN PUMP
450106	CLAMP FE ZN 32-44 H=12,2
450114	CLAMP FE ZN.22-32 H=12,2
630139	DRAIN PUMP VOLUTE WITH FILTER

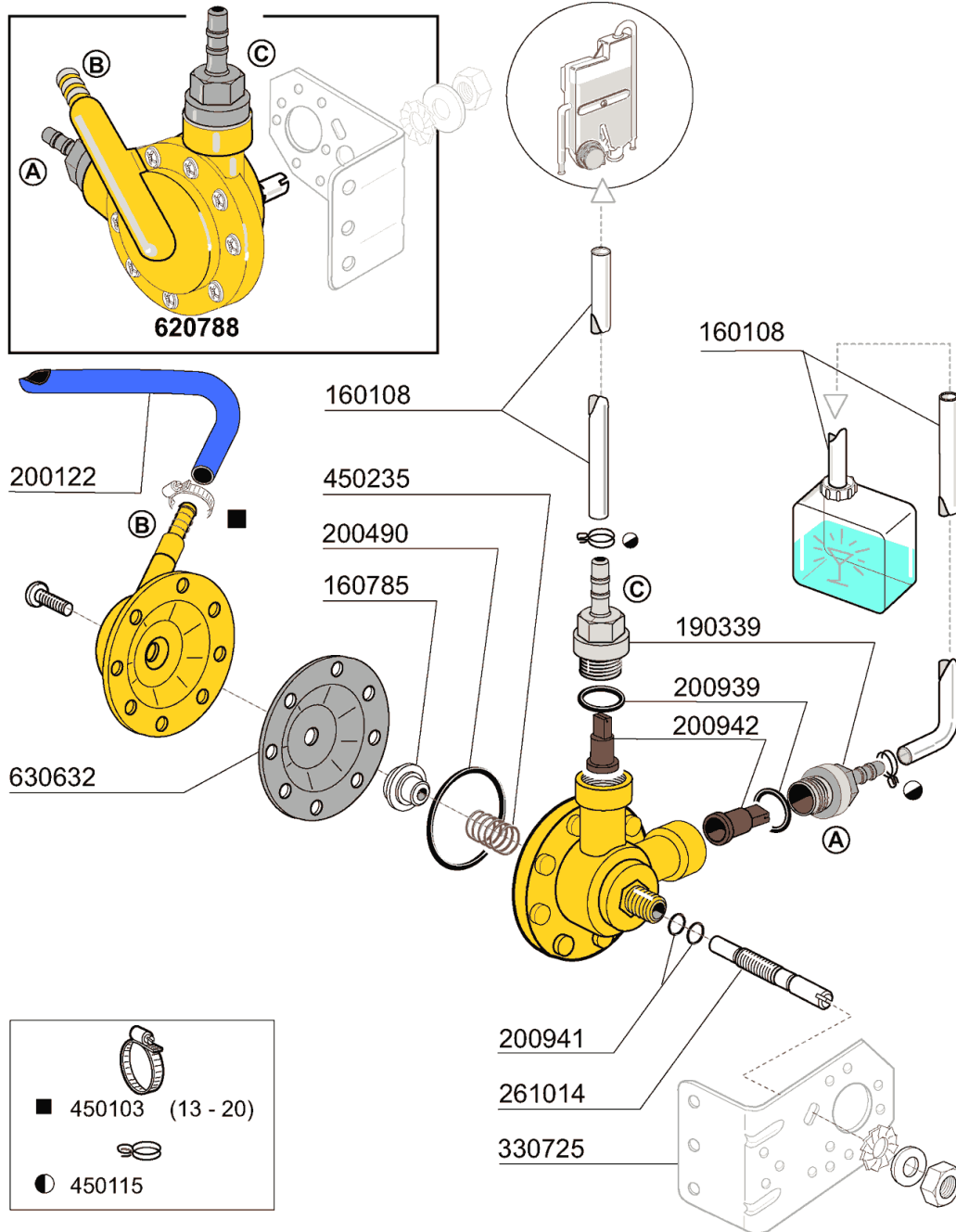

04 - 2007 | S. AG.

10 - Rinse aid injector

CODE	DESCRIPTION
160108	INJECT.INLET HOSE D.8X5
160785	GUIDE FOR SPRING RINSE AID INJ
190339	RINSE AID INJECTOR CONNECTION
200122	HOSE 11X19
200490	PROTECTION GASKET MOD.ADV.
200939	OR GASKET
200941	OR GASKET
200942	VALVE RINSE INJECTOR HVD
261014	SCREW
330725	STANDARD BRACKET F.SOLEN.VALV
450103	CLAMP FE ZN. 13-20 H=9
450115	ELASTIC CLAMP D.8,3/7,8
450235	SPRING RINSE AID INJECTOR
620788	RINSE AID INJECTOR H21428
630632	DIAPHRAGM RINSE INJECTOR HVD

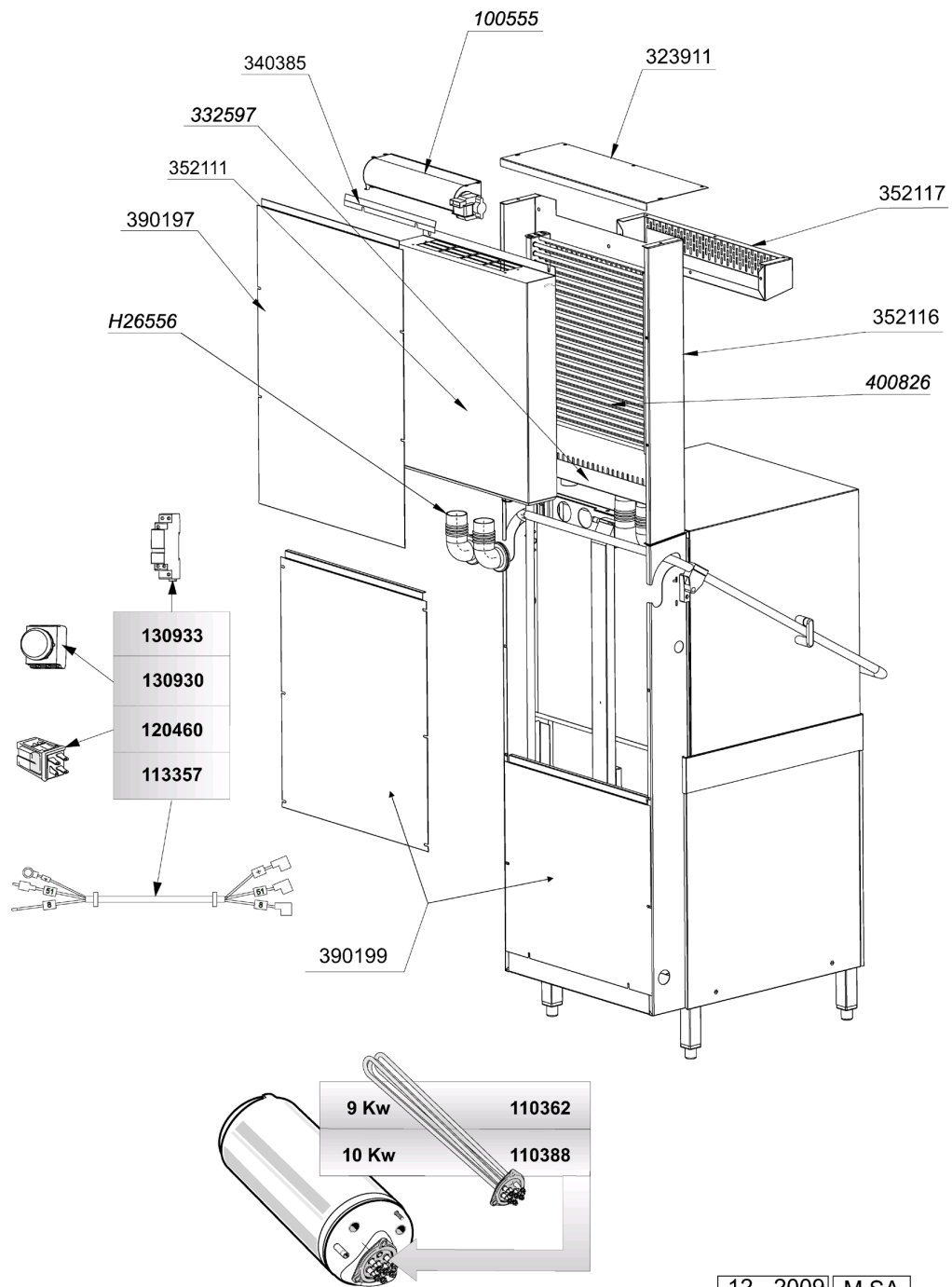

CODE	DESCRIPTION
100555	FAN TGA60/1 360-30
110362	HEAT.ELEMENT 9000W 220/380V
110388	HEAT.ELEMENT 10000W 230/400V
113357	CABLE FOR CRC
120460	RELAY 16A 220V
130930	CONTACT ABB 1NO/1NC 180"
130933	SUPPL. CONTACT NO/NC ABB
323911	CAPPELLO SUP CAPOT CRC PER XLC
332597	COLLETTORE ASPIRAZ. CRC C2001
340385	PARATIA VENT."POST" CRC C2001
352111	BACK PANEL CRC
352116	BACK PANEL CRC
352117	FRONT PANEL CRC
390197	BACK COVER CRC
390199	BACK PANEL XLC
400826	CRC BATTERY
H26556	HOSE